

Wire adjustment hanging bracket
ULTIMA Line Grip



ULTIMA



This is where Ultima's history began. Uniquely developed one-touch adjustable suspension fittings

This is an adjustable suspension fitting originally developed by Ultima for wires and other wire materials.

It is designed not only to handle heavy objects, but also to absorb shocks, shaking, and other usage conditions within a greater safety factor.

U-grip is used in various fields as parts of industrial machines and construction parts because of its easy wire attachment/detachment and position adjustment.

In particular, U-Grip is highly evaluated for its unparalleled ease of use, such as its strong locking action, high strength, and easy-to-install shape.

U-Grip is used as an inspection jig by Shimano, the world's largest manufacturer of bicycle parts.



Source: Shimano Inc. facebook page

Shimano Inc. holds about 70% of the world market share as a bicycle parts manufacturer.

Our products are used as inspection jigs for Shimano's bicycle wires (brake cables, shift cables, etc.).

In other words, Shimano's internal strength standards for wires are all determined by Ultima grips.

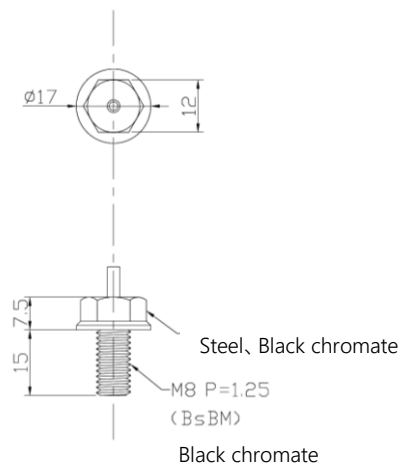

Delivered Products	ULG-1508 (Wire diameter 1.5mm)、ULG-1508S (Wire diameter 1.2 mm dia.)
Commencement of transactions	Since 1992

Main applications

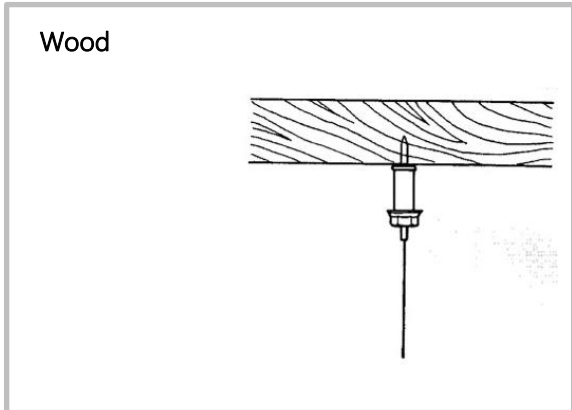
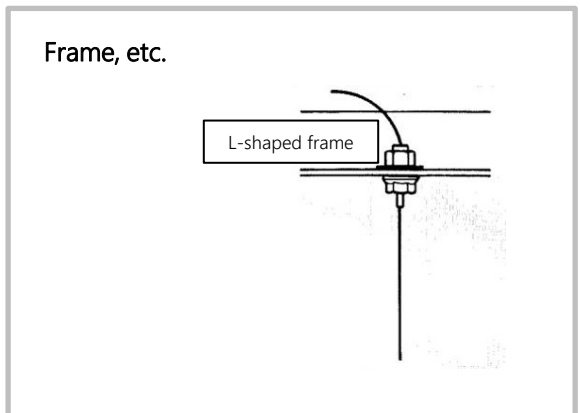
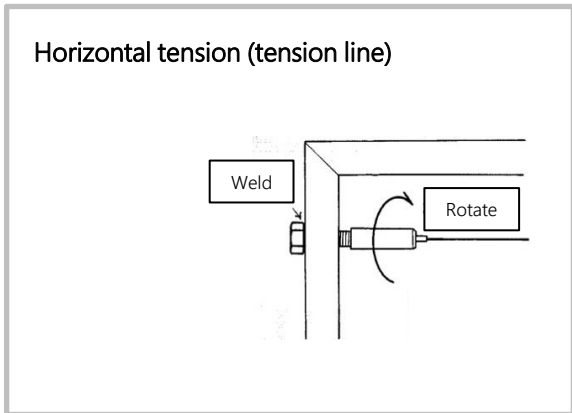
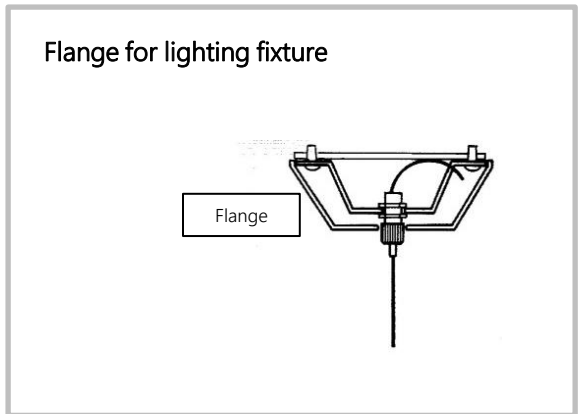
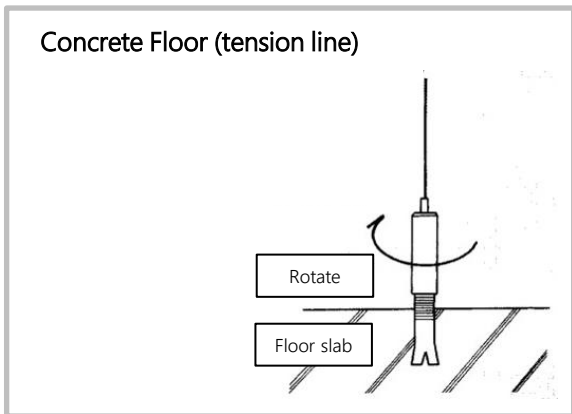
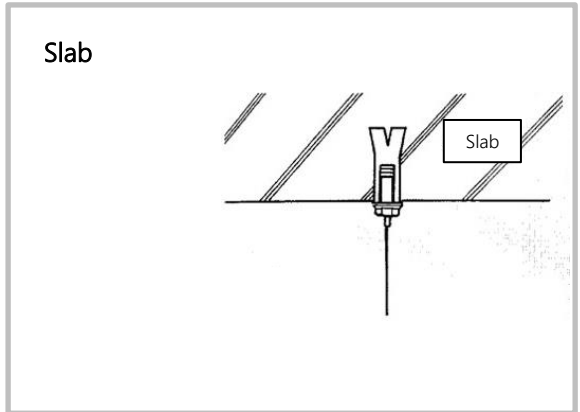
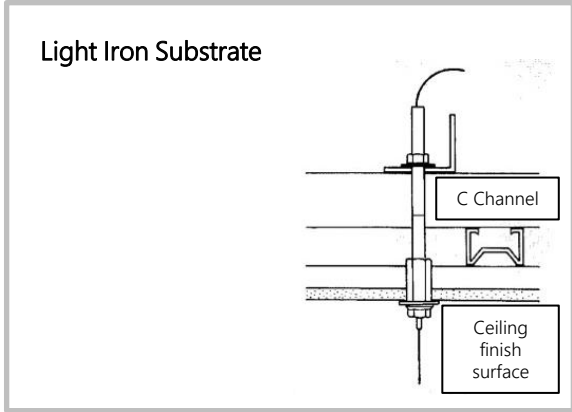

In addition to the examples above, other commercially available products such as eye nuts, hexagon socket set screws, T nuts, etc. can be used.

Grips can be used within the allowable load, but if the strength of the fixing method is low, the strength is defined by that strength. Please note the following



- It is designed not only to handle heavy objects, but also to absorb real-life usage conditions such as "shock" and "shaking" within a greater safety factor.
- Because of the ease of attaching and detaching wires and adjusting wire positions, they are used in a variety of fields as industrial machinery parts and construction parts.
- They have earned a reputation for their unparalleled ease of use, especially for their strong fixation, high strength, and easy-to-integrate shape.

Wire	Φ0.3~φ0.81、φ1.2、φ1.5、φ2.5
Allowable load value	Within 600 g to 150 kg * Allowable load values vary depending on the wire diameter * Allowable load values are based on a safety factor of approximately 1/3 of the maximum static load value.
Main applications	Hanging lighting, fixing equipment, store staging, inspection fixtures, etc.
Main customers	Banks, hotels, airports, stations, hospitals, universities, electrical equipment and materials companies, lighting equipment companies, and many others



Hanging decoration

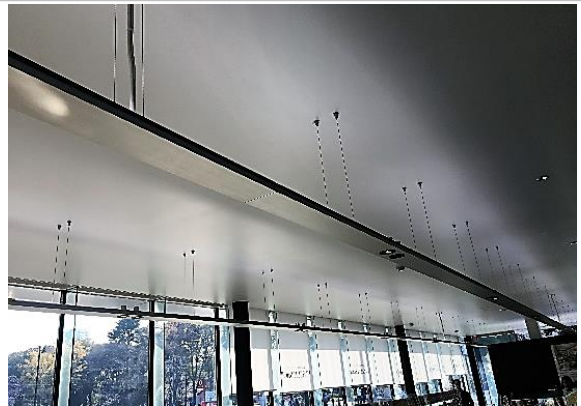

Hanging lighting

Features

One-touch locking and adjusting function	<ul style="list-style-type: none">• Lock by simply inserting the wire. Unlock by operating the pin.• This simple operation reduces installation time and improves repair work efficiency.
High strength	<ul style="list-style-type: none">• The maximum static load of the grips is almost equal to the JIS standard for wires. It can be used within a sufficient safety factor. *1
Wire-friendly	<ul style="list-style-type: none">• The internal locking mechanism reduces damage to the wire and makes it safer, especially in the event of an impact.
Open design concept	<ul style="list-style-type: none">• Standard dimensions for easy incorporation into the design allow the use of commercially available nuts and anchors.
Compact design	<ul style="list-style-type: none">• The uniquely compact body expands the range of use.

*1 Japanese Industrial Standard

Attention

- The grips have a strong locking force, so it may take more force to unlock them after a load is applied, but even if they are released strongly, the locking function will not be affected again.
- Because the grips have an internal mechanism, the torque value is lower than that of normal bolts. Do not over-tighten.
- If the cut end of the wire is untwisted, it will be difficult to get into the grip. Make sure the wire is cleanly cut and twisted.
- Cut the wires cleanly and twist them into the grips to ensure smooth insertion.
- Cut the excess wire that comes out of the grip, leaving 40 to 50 mm of excess wire. Please note that if the excess wire is forced and bent, it may affect the locking function.
- For safety reasons, do not use damaged or bent wires.
- Do not apply paint or oil to this product.

What makes Ultima Line grips different from standard wire grips?

Difference from common wire grips.

It is a thinner wire with a smaller wire diameter, which allows you to hang heavy objects safely.

This is because the gripping mechanism of the hanger hook is different from that of ordinary hanger hooks.

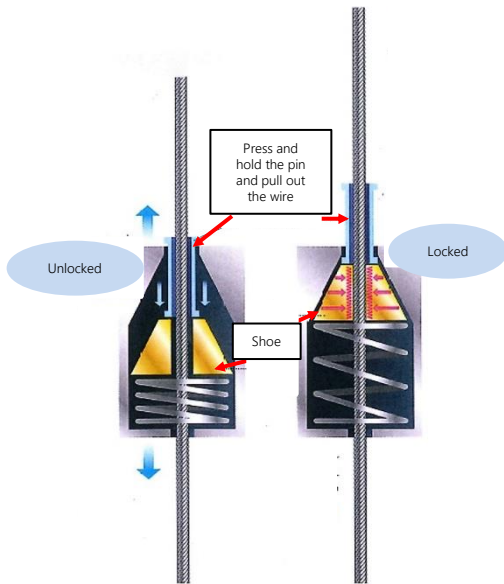

ULTIMA grip : Shoe type grip

Shoe type grips (surface fixation) distribute the load by clamping the wire between two surfaces, thereby reducing the load on the wire. The original strength of the wire is maintained.

The shoe-type grip is a proprietary technology of Ultima.

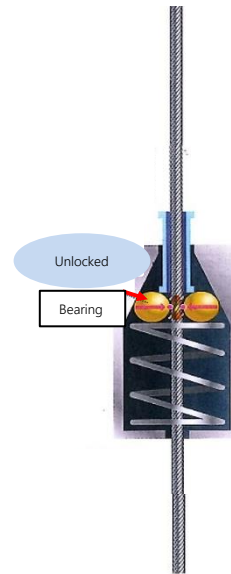

Other grip : Bearing type grip

Bearing type grips (point fixation) have less braking force because the force is concentrated at a single point, and the wire is easily damaged. The wire is easily damaged.

Safety	○	<ul style="list-style-type: none"> High strength and high safety ratio Utilized in industrial products 	△	<ul style="list-style-type: none"> Often utilized in display and interior design
Strength	○	<ul style="list-style-type: none"> Surface contact Strong grip, especially resistant to vibration *1 	×	<ul style="list-style-type: none"> Point contact Grip strength is low. Weak against shock and vibration *2
Release	×	<ul style="list-style-type: none"> Grip force is strong. Difficult to release by hand (finger) *3 	○	<ul style="list-style-type: none"> Grip force is low Easy to release by hand (finger)
Burden on wire	○	<ul style="list-style-type: none"> Surface fixation Less burden due to distributed load Less damage and indentation such as strand breakage and waviness 	×	<ul style="list-style-type: none"> Point fixation Load is concentrated, so there is a heavy burden. Damage and indentation such as strand breakage and waviness are inevitable. Wire maintenance is necessary
Production	○	<ul style="list-style-type: none"> Original design, not an off-the-shelf product Other companies cannot easily manufacture (difficult to manufacture equivalent products) 	×	<ul style="list-style-type: none"> Uses off-the-shelf bearings Easy to manufacture

*1 : 90% to 100% of JIS standard wire breaking load of 170kg based on SUS304p1.5mm (7*7) wire test values.

*2 : 50-70% of 170kg of JIS standard wire breaking load based on SUS304p1.5mm (7*7) wire test value.

*3 : Hybrid mechanism (pat.p) is also available to solve the disadvantage of difficulty in releasing the gripping force.

Basic grip operation

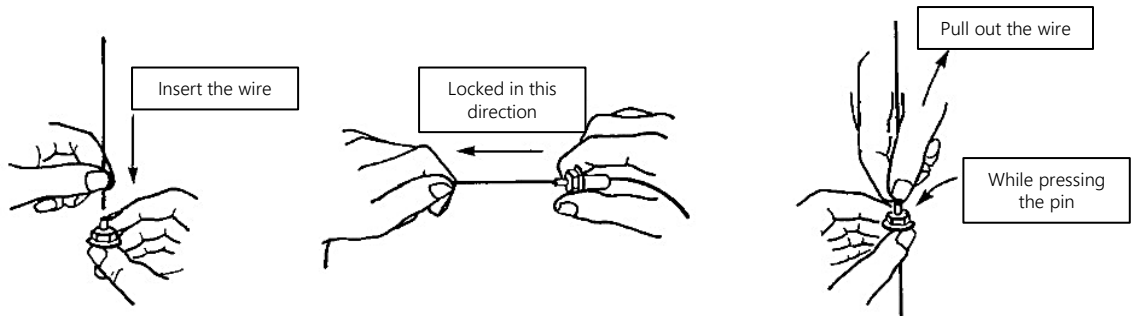

Grip strength

Wire	Maximum Static Load Value	Allowable Load Value
Φ0.36	29N~39N (3kg~4kg)	6N (600g or less)
Φ0.54	128N~137N (13kg~14kg)	30N (3kg or less)
Φ0.81	285N~314N (29kg~32kg)	60N (6kg or less)
Φ1.2	<u>1090N~1180N (111kg~120kg)</u>	<u>390N (40kg or less)</u>
Φ1.5	<u>1670N~1880N (170kg~192kg)</u>	<u>540N (55kg or less)</u>
Φ2.0	<u>2549N (260kg)</u>	<u>780N (80kg or less)</u>
Φ2.5	<u>4380N~4830N (447kg~493kg)</u>	<u>1470N (150kg or less)</u>

* The maximum static load value is the maximum value when a stainless wire (7 x 7) is used for the grip in a stationary state and pulled until the wire breaks (when it breaks).

* The allowable load is calculated with a safety factor of approximately 1/3 of the maximum static load value, but the safety factor should be considered depending on the conditions of use.

* The maximum static load value varies depending on the type of wire used. Please contact us if you have any questions.

Comparison of allowable load value by wire diameter

Wire	<u>ULTIMA grip : Shoe type grip</u>	Other grip : Bearing type grip
Φ1.2 *1	40kg	10kg
Φ1.5 *2	50kg ~ 65kg	30kg

* The allowable load is calculated with a safety factor of approximately 1/3 of the maximum static load value, but the safety factor should be considered depending on the operating conditions.

*1 Allowable load for stainless steel wire specifications.

*2 Allowable load differs depending on the type of hanger hook.









Wire set







To combine Ultima Line Grip, simply select the grip (wire clamp) and the wire end part that matches the installation location.

※ Allowable load for stainless steel wire: $\phi 1.5$ is 55 kg, $\phi 1.2$ is 40 kg. Allowable load for coated wire: $\phi 1.2$ is 10 kg.

※ Wire length: Please select from L=1,000 or L=1,500.

※ Each set consists of 1 grip and 1 wire.

ULTIMA Line Grip Wire set $\phi 1.5$			$\phi 1.5$ ULG wire set											
Product			A	B	C	D	E	F	G	H	I	J	K	L
Grip		ULG-1208 G	1 set	1 set										
		ULG-1508			1 set	1 set								
		ULG-1570					1 set	1 set						
		ULG-1560							1 set	1 set				
		ULG-1508 B									1 set	1 set		
		WG-1509											1 set	1 set
Wire		$\phi 1.5$ ball terminal wire on one side	1 set		1 set		1 set		1 set		1 set		1 set	
		$\phi 1.5$ wire with thimble bracket in one side		1 set		1 set		1 set		1 set		1 set		1 set

ULTIMA Line Grip $\phi 1.2$			$\phi 1.2$ ULG wire set											
Product			A	B	C	D	E	F	G	H	I	J		
Grip		ULG-1208	1 set	1 set										
		ULG-1508 S			1 set	1 set								
		ULG-1570 S					1 set	1 set						
		ULG-1560 S							1 set	1 set				
		ULG-1508 BS									1 set	1 set		
Wire		$\phi 1.2$ ball terminal wire on one side	1 set		1 set		1 set		1 set		1 set			
		$\phi 1.2$ wire with spring loop in one side		1 set		1 set		1 set		1 set		1 set		

* U-grips are designed with a limited wire diameter for safety, even though the external shape is the same. Please note the part number when ordering. For improvement, the shape and specifications are subject to change without notice.

Product Specifications (wire : ϕ 1.5、 ϕ 1.2)



	ULG-1208 G	ULG-1208	ULG-1508	ULG-1508 S	ULG-1570	ULG-1570 S
Wire	ϕ 1.5	ϕ 1.2	ϕ 1.5	ϕ 1.2	ϕ 1.5	ϕ 1.2
Allowable load	<u>540N (55kg)</u>	<u>390N (40kg)</u>	<u>540N (55kg)</u>	<u>390N (40kg)</u>	<u>540N (55kg)</u>	<u>390N (40kg)</u>
Material	brass		brass, steel		brass, steel	
Finishing	trivalent chromate		black chromate		black chromate	
Screw	M8 P=0.75		M8 P=1.25		with outer case for ϕ 4 screws	
Color	-		black		black	
Note	Sold separately : decorative nuts (Fabric, Cr.), tube nut (fine)		Sold separately : standard nut (coarse)		-	



	ULG-1560	ULG-1560 S	ULG-1508 B	ULG-1508 BS	ULG-1509
Wire	ϕ 1.5	ϕ 1.2	ϕ 1.5	ϕ 1.2	ϕ 1.5
Allowable load	<u>540N (55kg)</u>	<u>390N (40kg)</u>	<u>540N (55kg)</u>	<u>390N (40kg)</u>	<u>540N (55kg)</u>
Material	brass		brass, steel		brass, steel
Finishing	coating		Bolt part : Uni-chrome plating Grip part : Black chromate		Uni-chrome plating
Screw	M10 P=1.5 (internal thread)		M8 P=1.25		W3/8" -16
Color	black		black		-
Note	Tension function type		with washer and nut		Sold separately : nut

Product Drawing

ULG-1208G (φ1.5), ULG-1208 (φ1.2)

grip	decorative nuts	tube nut
------	-----------------	----------

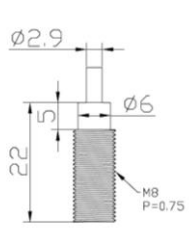

BsBM
trivalent chromate

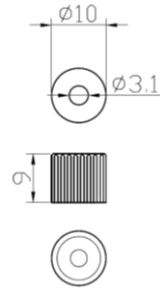

BsBM
chrome plating

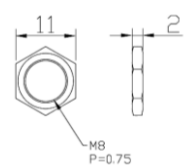

steel
trivalent chromate

ULG-1508 (φ1.5), ULG-1508S (φ1.2), ULG-1570 (φ1.5), ULG-1570S (φ1.2)

grip	outer case for Φ4 screws (ULG-1570, 1570S)
------	--

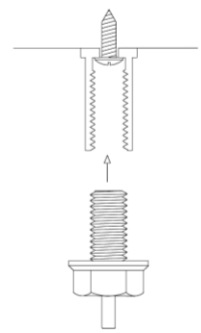
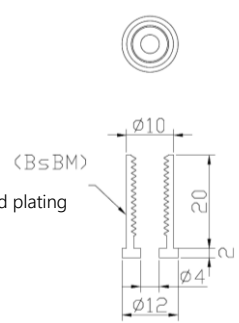
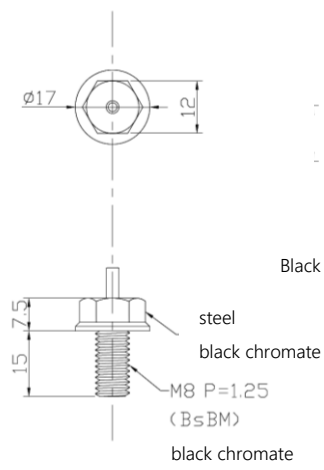

ULG-1560 (φ1.5), ULG-1560S (φ1.2) WG-1509 (φ1.5)

grip

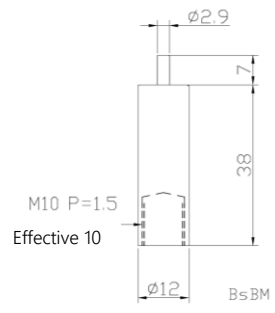

Black baked plating

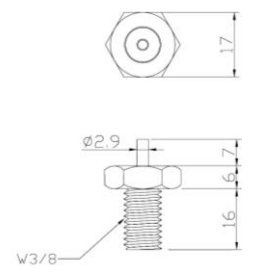

BsBM
Steel (Uni-chrome plating)

ULG-1508B (φ1.5)、ULG-1508BS (φ1.2)		
finished	bolt	grip

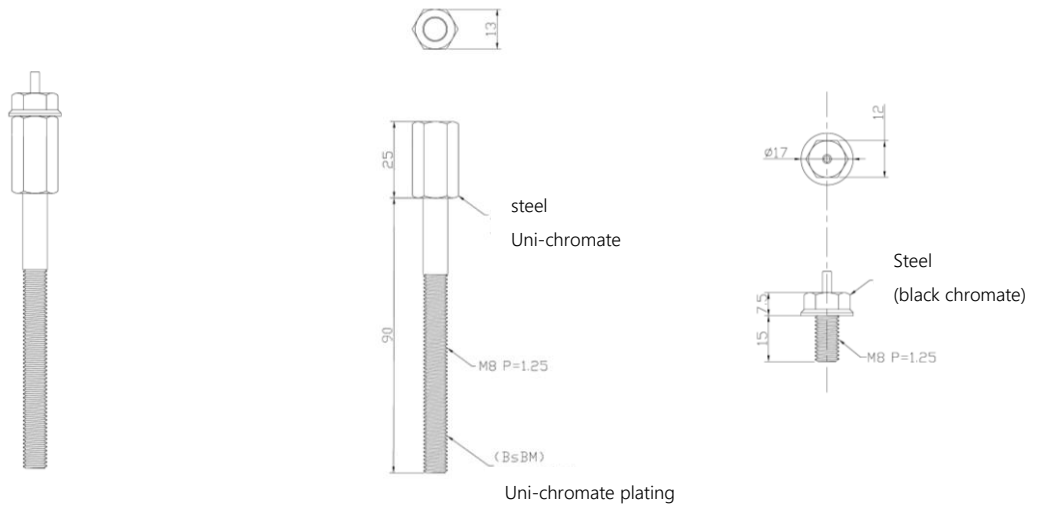

Product Specifications (wire : φ1.5、φ1.2)

ball terminal wire on one side	thimble bracket in one side	spring loop in one side
--------------------------------	-----------------------------	-------------------------



Wire	φ1.5、φ1.2	φ1.5	φ1.2
Material	SUS304 (7×7)	SUS304 (7×7)	coating
Wire Length	L=1,500、1,000		

* Do not use any wire other than the special wire provided by our company.
 * Standard wire grip dimensions are L=1,000 and 1,500. Please consult us for other dimensions.

FAQ

Q1. What is the allowable load for grips?

It ranges from within 600g to 150kg. The allowable load value is set at a safety factor of approximately 1/3 of the maximum static load value, and the allowable load value varies depending on the wire diameter. For details, please refer to P.9 Grip Strength.

Wire	Maximum Static Load Value	Allowable Load Value
Φ0.36	29N~39N (3kg~4kg)	6N (600g or less)
Φ0.54	128N~137N (13kg~14kg)	30N (3kg or less)
Φ0.81	285N~314N (29kg~32kg)	60N (6kg or less)
Φ1.2	<u>1090N~1180N (111kg~120kg)</u>	<u>390N (40kg or less)</u>
Φ1.5	<u>1670N~1880N (170kg~192kg)</u>	<u>540N (55kg or less)</u>
Φ2.0	<u>2549N (260kg)</u>	<u>780N (80kg or less)</u>
Φ2.5	<u>4380N~4830N (447kg~493kg)</u>	<u>1470N (150kg or less)</u>

Q2. Can you handle wire diameters other than the existing φ1.2 and 1.5?

The wire diameters used are limited. Please do not use wire diameters other than the specified ones for safety reasons.

Q3. Can I also purchase tube nuts and decorative nuts?

For some products, pipe nuts and decorative nuts that match the screws are sold separately. Please inquire at the time of order.

ULG ULTIMA Co.,Ltd.
Ultima Line Grip